



VENT-CAPTOR 3202.30

Flow meter for gaseous media

The vent-captor type 3202.30; ideal for all measurement and control tasks within automation processes and other industrial applications where gaseous media have to be controlled. The sensor works according to

the calorimetric measuring principle which allows the adjustment of the measuring range to a large quantity spectrum. The sensor operates fully electronically and without mechanically moved parts.

FEATURES:

- Precise flow measurement
- Adjustable measuring range
- Temperature independent
- Analogue current output 4 – 20 mA
robust industrial design (special encapsulation)
- ISO 9001 : 2015

CONNECTION DIAGRAM:

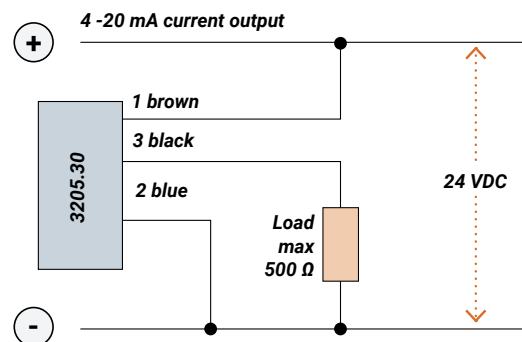

VENT-CAPTOR 3202.30

TECHNICAL DATA

Type	3202.30/xx
Medium	gaseous (aggressive media on request)

SENSOR DATA *1

Measuring range	0-5 m/s, - 10 m/s, - 20 m/s, - 30 m/s, - 40 m/s, - 50 m/s
Adjustable	continuously from 20 - 100 % by means potentiometer for zero point and range
Adjustment characteristics	linear to flow speed
Linearity deviation	< 5 % best fitting slope
Repeatability tolerance	< 3 %
Medium temperature	-20°C to +70°C
Ambient temperature	-20°C to +70°C
Pressure	with flange: atmospheric / with PG21: max. 1 bar
Temperature drift	< 0,3% K

MECHANICAL DATA

Protection class	IP 64
Material sensor probe	ceramic with overglaze
Material housing	Ultradur (PBTP)
Mounting accessories	flange (included in delivery) / PG21 on request
Electrical connection	2m oilflex cable / 3 x 0.5mm ²
Body dimensions	see drawing at bottom

ELECTRICAL DATA

Operating voltage	24 VDC ±30 %
Current output	4 - 20 mA
Load	max. 500 Ω
Power consumption	70 mA - 140 mA (max. flow)

**1 all data relate to medium air*

VENT-CAPTOR 3202.30

HOUSING DIMENSIONS:

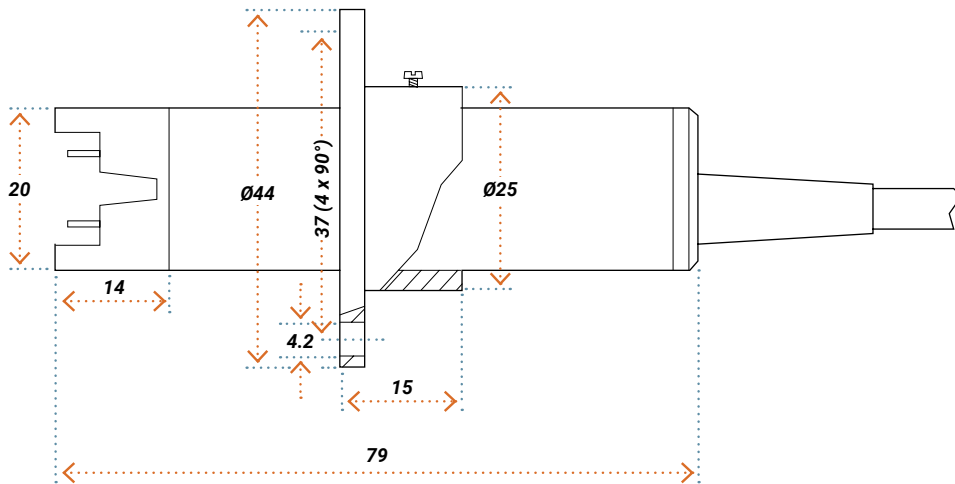

WITH PG21 PLASTICS

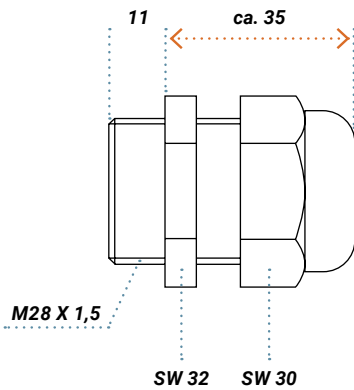

WITH PG21 METAL

